

# CQG/LAN Technical Specifications

September 1, 2011 | Version 2011-05

Copyright © 2011 CQG Inc. All rights reserved. Information in this document is subject to change without notice.

Windows XP, Windows Vista, Windows 7, Windows, ActiveX, Excel, and Visual Basic are either registered trademarks or trademarks of Microsoft Corporation in the United States and/or other countries.

Intel is a trademark of Intel Corporation in the U.S. and other countries.

---

# Table of Contents

---

About this Document .....	1
Publication History .....	1
Customer Support .....	1
Related Documents.....	1
CQG Integrated Client.....	2
CQG/LAN.....	2
Computer Specifications.....	3
Bandwidth Utilization .....	4
CQG Multiple Monitor Services .....	4
CQG Market Scan .....	4
Firewalls and Proxies .....	5
Network Communication .....	6
Client-to-Server Communication.....	6
Numbers of Servers Required .....	7
Architecture Diagram.....	8
Configuration 1 .....	8
Configuration 2 .....	9
Server Specifications .....	11
Dealing with Server Failure.....	12
CQG/LAN and Market Data .....	13
External IP Traffic .....	14
Installation.....	15
File Server.....	16
Entitlements and Permissioning.....	17
Client Load Leveling .....	18
CQG/LAN and Other Applications.....	19

---

# About this Document

This document provides the information you need to understand computer, server, and installation requirements; network communication; bandwidth use; and support of firewalls, proxies, and other software applications for CQG/LAN.

The most current version of this document is always available at:

<http://www.cqg.com/Docs/LANSpecLetter.pdf>

---

## Publication History

Date	Version	Changes
September 1, 2011	2011-05	Updated hard drive specifications.

---

## Customer Support

CQG Customer Support is available to help you. Please call us at 1-800-525-1085 or e-mail us at [websupt@cqg.com](mailto:websupt@cqg.com).

---

## Related Documents

CQG Integrated Client user guides can be found on our [website](#).

Other helpful documents can be found on our [Customer Education page](#).

# CQG Integrated Client

CQG Integrated Client has earned a solid reputation through decades of reliable performance, providing traders with an innovative trading interface complete with accurate global market data, professional analytical tools, and advanced order routing.

CQG/LAN software operates with Windows® 7, Windows Vista®, and Windows XP® and is available for the networked environment.

---

## CQG/LAN

CQG/LAN provides additional levels of flexibility and robustness for CQG IC:

- CQG/LAN can be installed on a network dedicated to CQG or it can operate on a shared network segment.
- CQG/LAN permits each CQG client to log on and off at their convenience.
- CQG/LAN delivers real-time data to each CQG client.
- CQG/LAN permits a CQG client to access the server from a remote location.
- CQG/LAN is architected to support redundant servers. If a single CQG/LAN server fails and an alternate CQG/LAN server is available on the network segment, the CQG client's connection is transferred to the alternate server.

CQG/LAN uses the industry standard TCP/IP-based transport and name resolution services supported by Winsock 1.1. Data delivery is via TCP/IP on an Ethernet network.

CQG/LAN client software consists of 32-bit Windows® applications developed for Intel X86® architecture computers.

# Computer Specifications

These specifications are appropriate for single and dual monitor set ups. If you have three or four monitors, you will need a higher performance processor, video card, and network connection.

	Required	Recommended
<b>Operating System</b>	Windows 7, Windows Vista, or Windows XP.	64-bit Windows 7.
<b>Processor</b>	Dual-Core. Intel Core 2 Duo (2.33GHz or better).	Intel Core i5 or i7.
<b>Memory</b>	4GB RAM.	6GB DDR3 SDRAM or more.
<b>Hard Drive</b>	200GB, 7200RPM with 4GB of free hard disk space.	500GB SATA 6.0Gbit/s HDD.
<b>Video Card</b>	Dual port graphics adapter with 128Mb of memory, 64Mb per port.	1GB DDR3 or better.

**Internet Access:** Internet service via a high-speed connection, such as DSL, cable, or fixed wireless/wireless local loop (WLL). Wireless internet connections not recommended, especially broadband over a wifi card. Dial up not supported.

**System Setting Requirements:** Hibernate and standby modes cannot be used on a system running CQG IC. Hard drive power-saving features should also be disabled.

# Bandwidth Utilization

CQG/NET requires approximately 20K bytes/sec sustained and an average 100K bytes/sec of additional bandwidth per user for burst mode. Optimal figures are 60K bytes/sec and 500K bytes/sec.

Because Ethernet performance degrades significantly when the network load exceeds 30%, the number of CQG clients per network segment should be limited to 60, given a normal distribution of quotes-only and technical analysis users. CQG would then consume approximately 2% of the available bandwidth, leaving sufficient reserve capacity for other network functionality.

Task	Duration	Bandwidth Usage
Startup	Short burst < 1 sec	30-50 kbps
	10-15 sec	3-5 kbps avg
Page change uncached, first time viewed	Short burst < 1 sec	5-30 kbps depending on page complexity
Page change cached, already viewed	Short burst < 1 sec	1-3 kbps
Page viewing	As long as page is displayed on screen	1-3 kbps avg sustained
Typical 10-min session including startup, shutdown, and multiple page changes	10 min	2-3 kbps avg

## CQG Multiple Monitor Services

CQG offers Dual Monitor Service, Triple Monitor Service, or Quad Monitor Service. Each additional monitor adds an additional amount of bandwidth usage, approximately equal to the figures shown in the above table. For example, a typical 10-minute session on a CQG system enabled for CQG Triple Monitor Service can be expected to use approximately 6-9 kbps averaged over the 10-minute period.

## CQG Market Scan

A CQG/NET system utilizes additional bandwidth when a market scan is executed. Scans are user-initiated and can run from several seconds to several minutes, over which time they use an average of approximately 10-50 kbps. CQG's Market Scan Service is optional.

# Firewalls and Proxies

## Firewalls

CQG/LAN supports the following firewall configurations:

- Network address translation
- Dynamically assigned ports on the client side

## Proxies

Socks 4 and 5 proxies are supported as well as a Winsock redirector, such as Microsoft® Proxy Server 2.0.

---

# Network Communication

---

## Client-to-Server Communication

Use	Protocol	Client Source Port	Server Destination Port
Client/server communication	TCP	System-assigned	2823, 2824

- All traffic between CQG clients and servers use the TCP protocol. The UDP protocol is not used.
- All network connections between CQG clients and servers are initiated from the client side. No connections are established by the server.
- Destination port numbers at the server side are 2824 (CQG's registered port number).
- Source ports at the client side are always system-assigned port numbers in the 1025-5000 range.
- CQG client services, such as News and IM, may be configured for indirect access via server proxy located on the server by specified address/port.

---

# Numbers of Servers Required

CQG requires that a minimum of two servers be installed.

A CQG/LAN installation plan should take into account possible [server failure](#). If it is unacceptable to have any of your users down or at risk because of a server failure, then an additional server is required. We recommend the following redundant installation:

Number of Users	Number of Servers
1 to 60	2
61 to 120	3
121 to 180	4
181 to 240	5
Each additional 60 users	1 additional server

A large percentage of power users can greatly reduce the number of users per server.

# Architecture Diagram

## Configuration 1

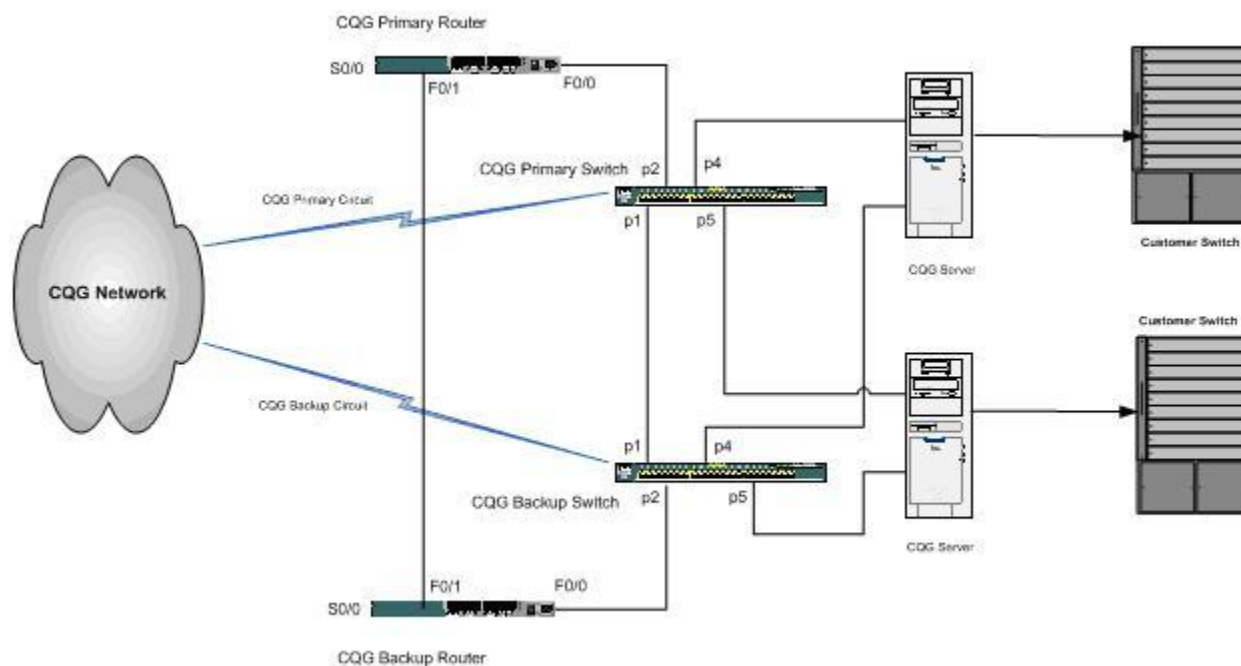

Each CQG Server requires three network interfaces:

- NIC 1: CQG Primary Data Feed
- NIC 2: CQG Backup Data Feed
- NIC 3: Customer Network Connection

Additional connections:

- COM 1: CQG Security Device
- COM 2: Router Console Port Connection

## Configuration 2

This configuration is for CQG/LAN with added trade routing and news functionality.

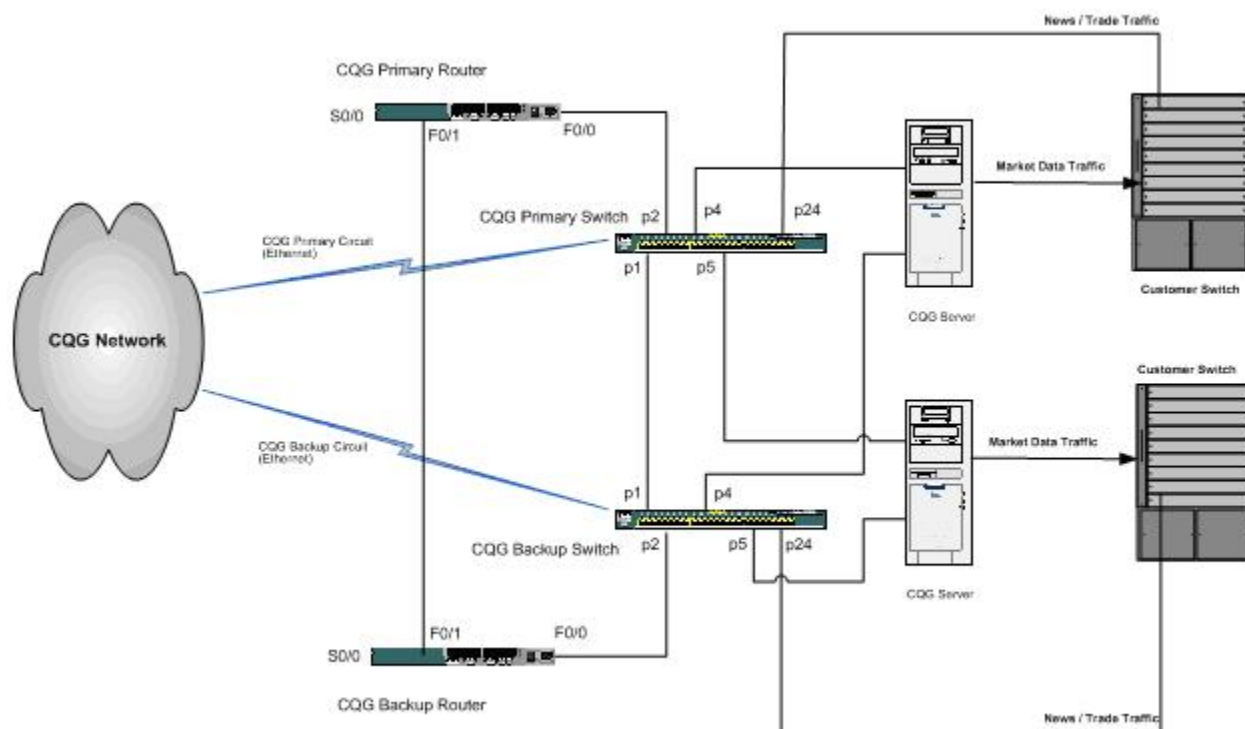

Refer to Configuration 2 if electronic trade routing and news are to be deployed for CQG clients.

Six additional IP address will be required for this configuration:

- CQG Primary Interface
- CQG Backup Interface
- CQG HSRP
- CQG News
- Trade routing
- Trade routing

Each CQG Server requires three network interfaces:

NIC 1: CQG Primary Data Feed

NIC 2: CQG Backup Data Feed

NIC 3: Customer Network Connection

Additional connections:

COM 1: CQG Security Device

COM 2: Router Console Port Connection

# Server Specifications

The CQG/LAN Server runs on 100% IBM®-compatible hardware that meets the following requirements:

<b>Processor</b>	Intel®-based dual quad-core processors with 2.5Ghz minimum.
<b>Operating System</b>	Windows 2003.
<b>RAM</b>	4GB RAM.
<b>Hard Drive</b>	Four 300GB or greater SCSI hard drives in RAID 0 configuration. After installation of CQG server software, 10GB of free space is required.
<b>CD-ROM</b>	Quad speed or better.
<b>Serial Port 1</b>	A dedicated High Speed Communications Port equipped with 16550A UART. Chip for connection to the CQG SECDEV.
<b>Network adapter 1</b>	Required: Ethernet – 10BaseT for CQG data, primary communication.
<b>Network adapter 2</b>	Required: Ethernet – 10BaseT for CQG data backup.
<b>Network adapter 3</b>	Required: Ethernet – 100BaseT for CQG server-to-server communications.

A minimum of two servers, each with four network adapter cards (NIC), are required in this CQG/LAN environment.

# Dealing with Server Failure

CQG/LAN is architected for robustness through symmetrical redundancy. Each server is capable of performing every system function, including acting as the active login server. Failover is triggered automatically when critical inter-server communications are interrupted for longer than the permitted time-outs.

If one CQG/LAN server fails, the CQG client's connection is automatically transferred to another CQG/LAN server, guaranteeing uninterrupted access to [market data](#).

# CQG/LAN and Market Data

CQG broadcasts market data to CQG/LAN servers using IP multicast communications over a dedicated leased line.

CQG server software can automatically fail over to a second dataline for market data.

A CQG SECDEV is connected to a CQG/LAN server's serial port for unique server identification.

# External IP Traffic

Currently, CQG/LAN does not use external IP connections.

# Installation

Because CQG/NET is a real-time, mission-critical application, we recommend that it and the working directory be loaded on a local hard drive.

For best performance, we recommend setting the working directory to a file server and not running CQG/LAN from an application server.

User-modified files are backed up daily by CQG.

You must register COM and ActiveX<sup>®</sup> components on the client system and install mdac 2.7 or higher and Microsoft .net framework 2.0 or higher.

**IMPORTANT:** User permissions on the main CQG folder and all subfolders and files must be set to "Modify" or "Full Control." Installing the CQG client application on a restricted drive and assigning it limited permissions, such as "Read & Execute," impede performance and may prevent CQG/LAN from functioning at all.

# File Server

A file server is recommended for storing unique configuration information about and for each CQG client.

The file server needs to provide access permission for the creation of new private directories for new CQG clients.

Network traffic is negligible. The file server must be accessible on the client side of a firewall.

**It is of utmost importance that a routine file backup policy is in place on the file server.**

# Entitlements and Permissioning

CQG remotely manages entitlements associated with CQG/NET. Each user has a specific set of entitlements that are accurately reflected in CQG's monthly billing. CQG is able to flag customer accounts to prevent any unauthorized entitlement.

CQG does not provide on-site entitlement management. CQG/LAN requires network enabled client workstations, network cabling, and other networking hardware provided by the customer. The customer has the option of supplying the servers or leasing the server equipment through CQG. IP addresses and other information necessary to install servers and workstations must be available at the time of installation.

Data is delivered to each server by a network connection. CQG supplies a security device (SECDEV) for each server which connects to its serial COM port, which allows CQG to manage the services available to each CQG client.

# Client Load Leveling

When a COG client logs on to a COG/LAN server cluster, the active login server allocates the client to the COG/LAN data server with the fewest users.

# CQG/LAN and Other Applications

The CQG client is DDE-compliant and can provide data to software such as Excel<sup>®</sup> and Visual Basic<sup>®</sup>.

CQG does not publish its data feed for general price databases.